

TECHNICAL DATA SHEET



Isothermal dehumidifier with summer integration designed for the control of indoor relative humidity in underfloor/ceiling/wall radiant cooling systems. It consists of a complete refrigerant unit with pre and post treatment hydronic batteries that can use the chilled water supplied to radiant systems. Galvanised sheet metal frame and stainless steel condensate tray, siphon on condensate drain mandatory. The unit is available in 2 versions, depending from the accessories used:

- version for embedded installation in the wall (composed by recessed box, dehumidification unit and front panel);
- version for external installation on the wall (composed by dehumidification unit and cabinet)

Description	Dimension	Weight	Code
RNW 200 PI	751x573x202 mm	29 kg	70RNWPI200

Components description

- **Compressor:** hermetically sealed with a bipolar single-phase asynchronous motor coupled with an alternative single cylinder compressor
- **Pre-cooling coil:** copper pipe and aluminium fins with hydrophilic treatment
- **Evaporating coil:** copper pipes and aluminium fins with hydrophilic treatment
- **Post-heating coil:** copper pipes and aluminium fins
- **Fan:** double suction centrifugal fan with with 3-speed directly coupled motor
- **Air filter:** with filtering material made of synthetic fibres, Class ISO Coarse 40% (G3)
- **Condenser temperature probe:** NTC sensor which measures the temperature of the condenser
- **Water temperature probe:** NTC sensor which measures the temperature of the water
- **Evaporator temperature probe:** NTC sensor which measures the temperature of the evaporator
- **Circuit board fuse:** 250v- 10 A
- **Plate exchanger:** B3Hx20
- **Valve:** 1/2" 3-way valve KVS 1.6

Package content

- RNW 200 PI
- Installation / Technical Manual

COMPONENTS

AIR FLOWS



Supply Air



Recirculation Air

AIR FLOWS



e(PM10) min ≤50 %
Hairs



Ø 14 mm Condensation Drain



1/2" F Hydraulic connection



Wiring Box

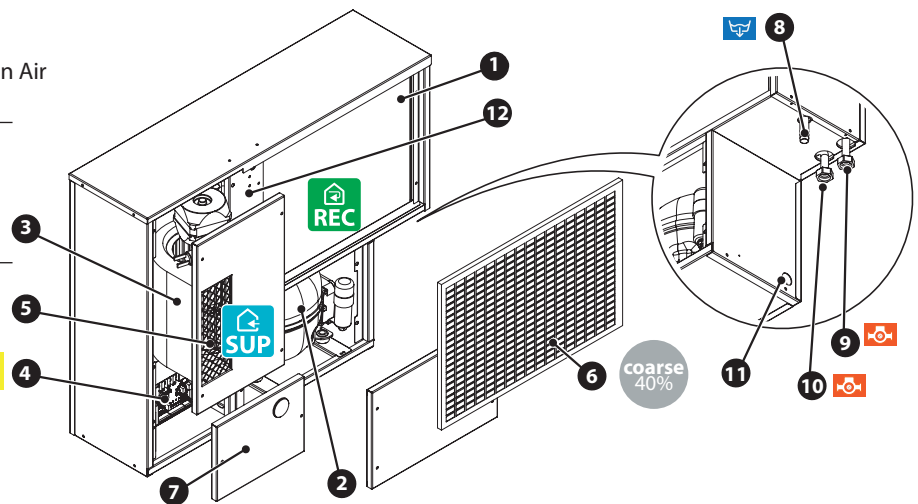

Rif.	Description	Rif.	Description
1	Exchangers	7	Switchboard
2	Compressor	8	Ø 14 mm condensation drain
3	Fan	9	Water inlet (1/2" F)
4	Electronic card	10	Water outlet (1/2" F)
5	Fan grille	11	Access to electric components
6	Filter for air inlet	12	Air vent (behind the filter)

SPARE PART

Air filter kit



RNW 200 PI FILTER KIT

Kit for complete replacement of unit filters containing:
- 1 ISO Coarse 40% filter - Size 460x320x10 mm

Code

7044130

TECHNICAL DATA SHEET

DIMENSIONS AND TECHNICAL DATA

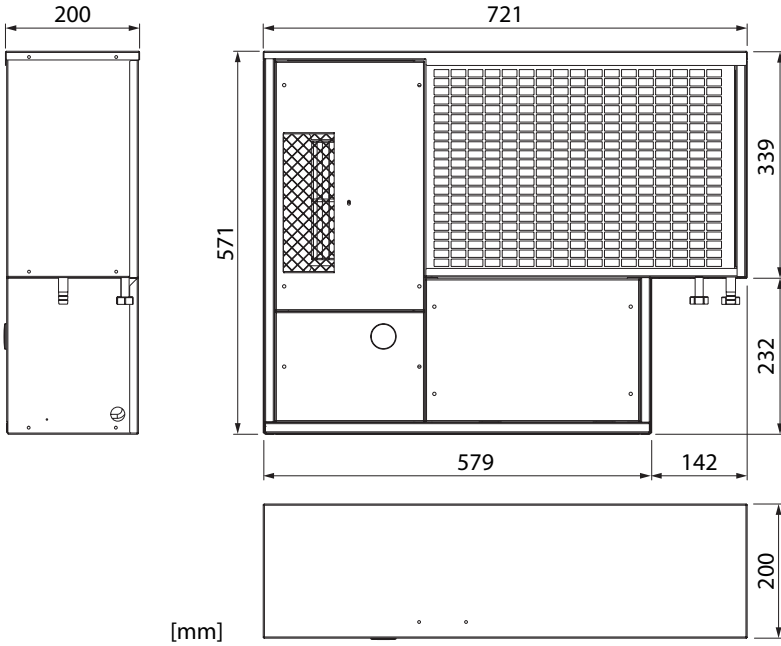

Overall machine dimensions		
Height	571	mm
Width	721	mm
Depth	200	mm
Weight	28,5	kg

Technical characteristics

Technical specifications

Condensation (26° - 65%)	21	l/day
Rated electrical power	340	W
Total water flow rate	240 (*)	l/h
Pressure loss on the hydraulic circuit	34	kPa
Nominal air flow rate (free outlet)	160	m ³ /h
Refrigerant R290 - GWP: 3	70	g
Carbon dioxide equivalent	0,00021	t

(*) Flow rate value with +20% and -20% than the mentioned value.

PERFORMANCE

The performance of the machine is directly related to the conditions of the incoming air and its flow rate, as well as the temperature and relative flow rate of the water.

Air		Water		Summary													
160 m ³ /h		240 l/h															
Pre-Treatment			Dehumidification								Integration						
[REC] Temp.	[REC] R.H.	[REC] Temp.	[SUP] Temp.	[SUP] R.H.	Condensation		Power		Total power		[SUP] Temp.	[SUP] R.H.	Power		Total power		
(°C)	(%)	(°C)	(°C)	(%)	(l/h)	(l/g)	LAT.	SEN.	AMB.	FRIG.	(°C)	(%)	LAT.	SEN.	AMB.	FRIG.	
26	65	18	24,2	50	0,86	21	601	97	698	781	18,0	74	601	434	1035	1507	
		15	22,3	50	1,04	25	735	200	934	1088	16,2	72	735	529	1264	1737	
		12	20	46	1,26	30	516	324	840	1395	14,2	72	516	638	1154	1102	
25	55	18	23,3	42	0,58	14	396	92	487	586	17,9	62	396	383	779	1361	
		15	22	46	0,65	16	459	162	621	642	16,7	63	459	448	907	1479	
		12	19	46	0,86	21	542	324	865	949	14,7	63	542	556	1097	1708	
27	60	18	24,6	50	0,83	20	578	130	707	698	19,9	64	578	383	961	1537	
		15	22	50	1,04	25	721	270	991	949	18,0	64	721	486	1206	1774	
		12	19,7	49	1,22	29	864	394	1258	1228	15,9	63	864	599	1463	2035	

TECHNICAL DATA SHEET

Air		Water	Summary															
160 m ³ /h		200 l/h																
Pre-Treatment		[REC] Temp.	Dehumidification								Integration							
[REC] Temp	[REC] R.H.		[SUP] Temp.	[SUP] R.H.	Condensation		Power		Total power		[SUP] Temp..	[SUP] R.H.	Power		Total power			
(°C)	(%)		(°C)	(%)	(l/h)	(l/g)	LAT.	SEN.	AMB.	FRIG.	(°C)	(%)	LAT.	SEN.	AMB.	FRIG.		
26	65	18	27	43	0,83	20	589	-54	535	698	20,3	64	589	308	897	1499		
		15	25,5	42	1,01	24	700	27	727	977	18,6	64	700	399	1100	1696		
		12	23	43	1,22	29	855	162	1017	1256	16,8	64	855	499	1354	1947		
25	55	18	25	39	0,58	14	400	0	400	628	18,0	62	400	378	778	1375		
		15	24	42	0,65	16	464	54	518	791	16,8	63	464	442	907	1491		
		12	21	43	0,83	20	574	216	790	1023	15,2	63	574	529	1103	1678		
27	60	18	27	44	0,76	18	532	0	532	721	20,5	64	532	351	883	1484		
		15	25	43	0,97	23	681	108	789	1047	18,6	64	681	453	1134	1726		
		12	22,9	42	1,15	28	817	221	1038	1279	16,6	66	817	561	1378	1967		

Tables legend:

- [REC]: Air-water inlet to the unit
- [SUP]: Supply air supply to the room
- R.H.: Relative Humidity
- LAT.: Latent Power
- SEN.: Sensible Power
- AMB.: Room Power
- FRIG.: Fridge Group Power

SOUND POWER LEVEL

Centre band frequency [Hz]																				
125			250			500			1000			2000			4000			8000		
100	125	160	200	250	315	400	500	630	800	1000	1250	1600	2000	2500	3150	4000	5000	6300	8000	10000
SPEED 1 (DEFAULT)																				
54,4	39,1	41,5	45,3	47,4	40,9	40,0	44,0	41,9	39,3	34,6	30,9	27,0	29,5	25,4	21,0	16,7	12,1	12,8	15,2	23,8
36,2			41,1			44,0			40,6			33,6			23,8			12,7		
47,5 dB (A)																				
SPEED 2																				
60,2	42,8	45,0	48,8	46,6	43,2	42,7	46,9	44,5	41,0	37,3	35,3	31,1	32,2	29,2	25,8	20,5	15,7	15,0	16,2	24,4
41,7			42,3			46,8			42,9			36,9			28,3			14,9		
50,2 dB (A)																				
SPEED 3																				
54,5	46,2	50,3	49,4	46,6	46,7	45,9	50,3	48,6	44,3	41,8	40,7	37,2	37,5	35,7	32,2	27,9	23,9	21,3	20,2	28,5
39,7			43,8			50,5			47,1			42,8			35,1			21,2		
53,4 dB (A)																				

CHARACTERISTIC CURVES

The fan is equipped with 3 speeds that can be selected by connecting the desired wire to the circuit board. The table below summarises the air flow rates in relation to the selected wire, for the electrical connection please refer to section "Electrical Connections" in the technical manual.

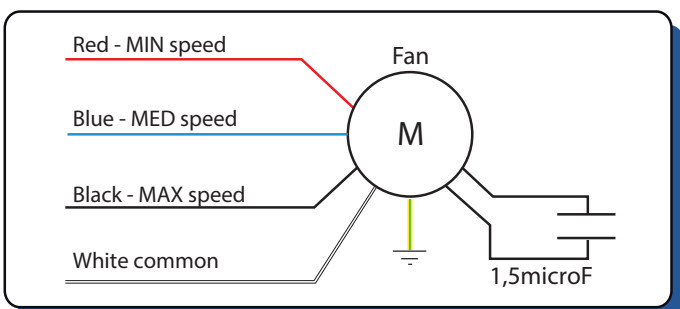

Fan speed variation	
Wires	Air Flow Rate
red + white (common)	160 m ³ /h
blue + white (common)	200 m ³ /h
black + white (common)	270 m ³ /h

TECHNICAL DATA SHEET

PRESSURE LOSS ON THE HYDRAULIC CIRCUIT

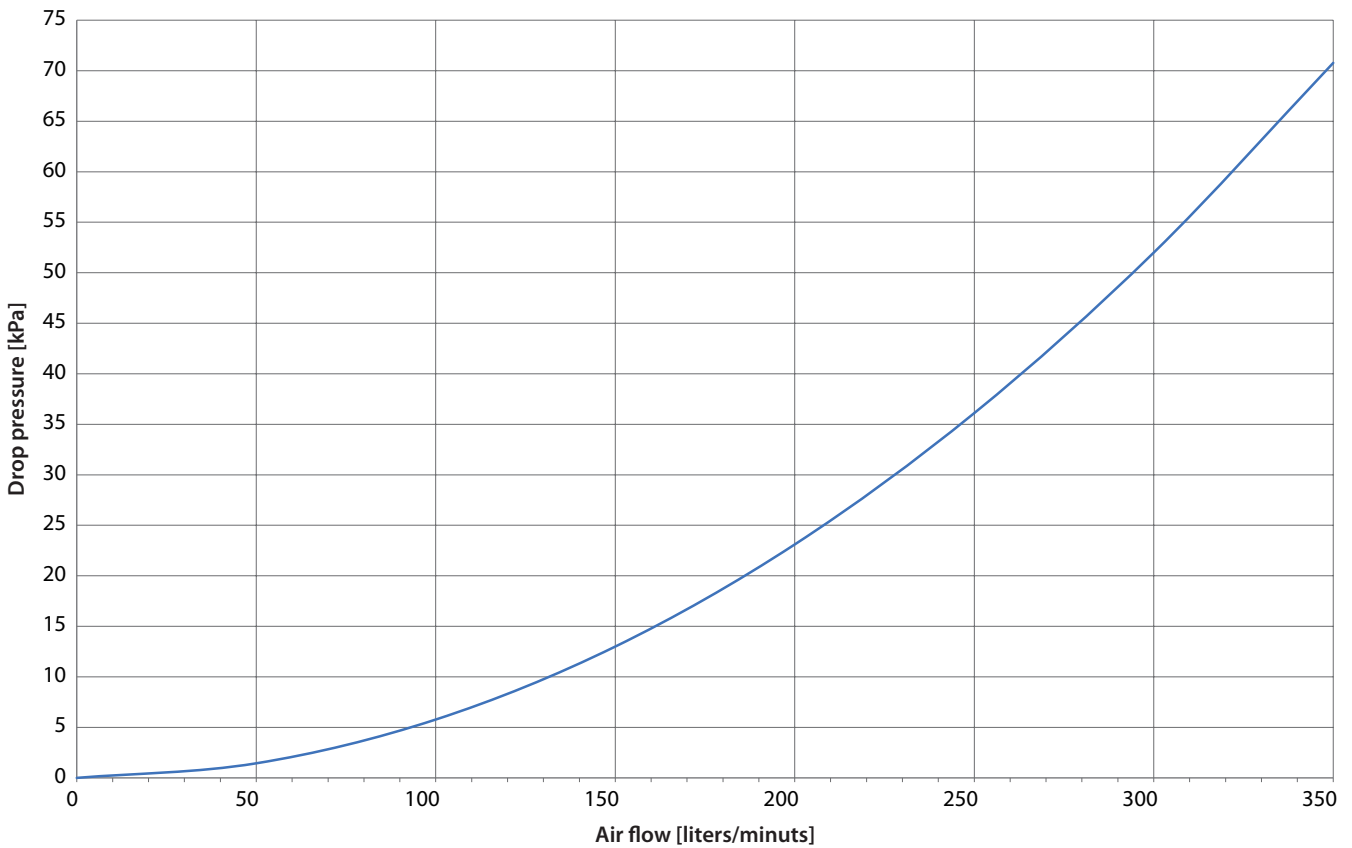

POSITIONING INDICATIONS

- Installation should only be carried out inside buildings.
- The dehumidifier must be installed in a place where air can circulate freely, avoiding being positioned at a dead angle, causing a short circuit in the air flow and failing to achieve the required dehumidification effect.
- The dehumidifier must be installed in a vertical position on a solid, flat wall.
- It is necessary to leave a free space of at least 3 m, from the front of the grille, for the free circulation of the dehumidified air.
- The unit should not be placed in rooms with high humidity, such as swimming pools, saunas, etc.
- Avoid positioning the unit with constant and direct exposure to sunlight or near heating.
- Avoid placing the unit in places where curtains could be placed in front of the dehumidifier, or at heights that could disturb the end user during operation.

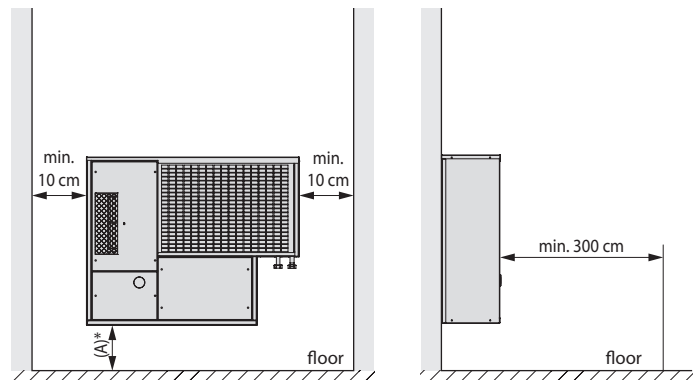
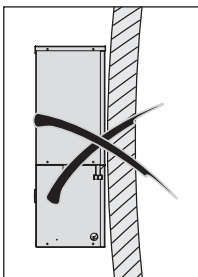
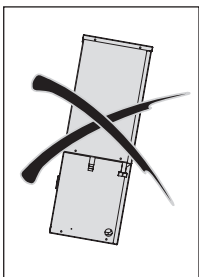
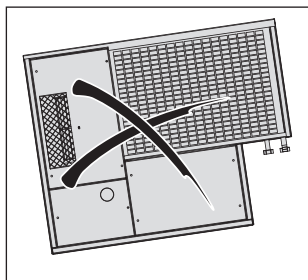
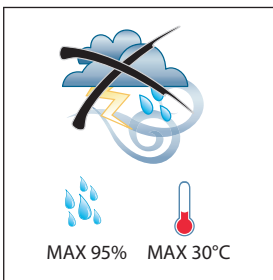

(A)*: it is possible to install the unit flush with the floor, however, to facilitate cleaning operations we recommend installation in a raised position, maintaining a height of at least 25 mm above the skirting board.

